

第五届河北省数控技能大赛数控铣工/加工中心实际操作试题

(学生组)

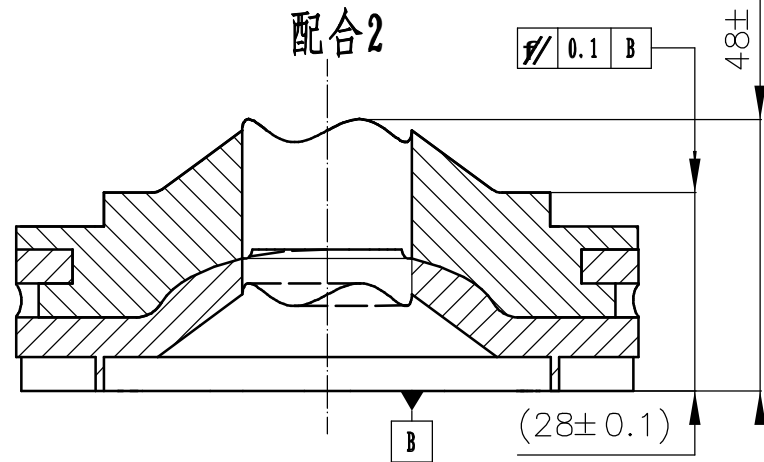
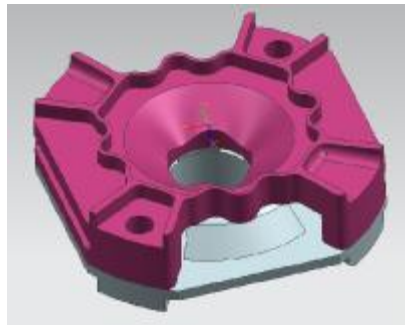
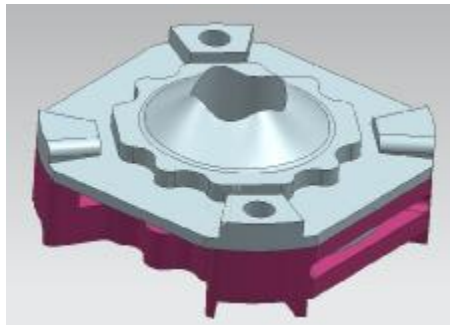
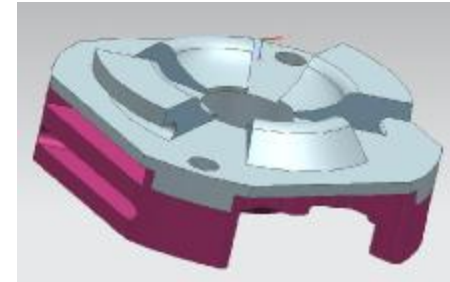
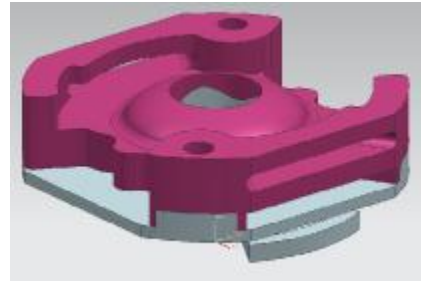
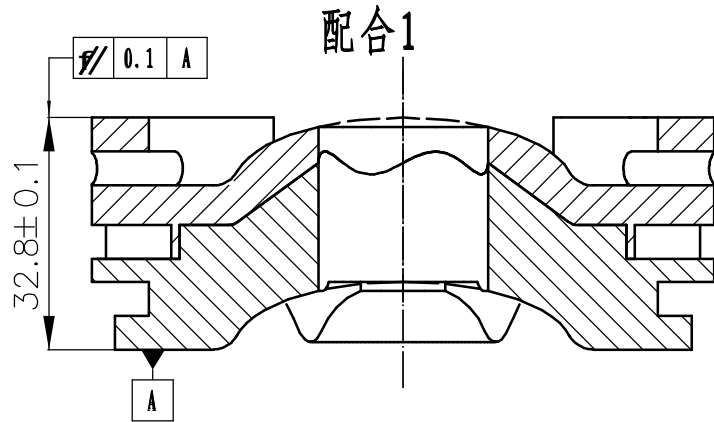

技术要求

配合1、2均要求实现 $\phi 10h7$ 销配

装配图		比例	
		材料	45
图号	X-1-3	数量	1